

SD230 SD250

Liquid Cooled Diesel Engine Generator Sets

Standby Power Rating

230KW 60 Hz /230KVA 50 Hz

250KW 60 Hz /250KVA 50 Hz

Prime Power Rating

185KW 60 Hz /185KVA 50 Hz

205KW 60 Hz /205KVA 50 Hz

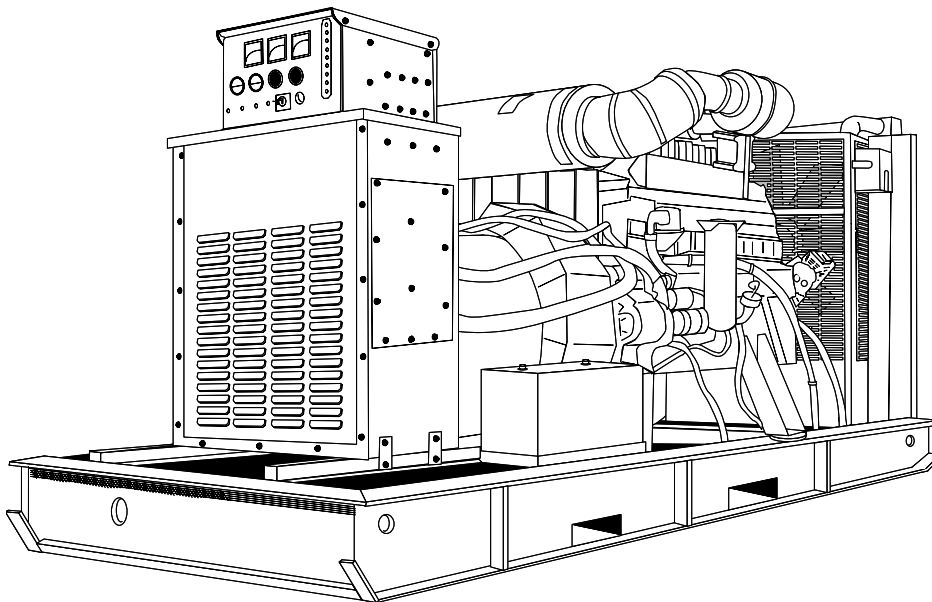

Power Matched

GENERAC 12.0DTA ENGINE

Turbocharged, Aftercooled

FEATURES

- **INNOVATIVE DESIGN & PROTOTYPE TESTING** are key components of GENERAC'S success in "IMPROVING POWER BY DESIGN." But it doesn't stop there. Total commitment to component testing, reliability testing, environmental testing, destruction and life testing, plus testing to applicable CSA, NEMA, EGSA, and other standards, allows you to choose GENERAC POWER SYSTEMS with the confidence that these systems will provide superior performance.
- **TEST CRITERIA:**
 - ✓ PROTOTYPE TESTED
 - ✓ SYSTEM TORSIONAL TESTED
 - ✓ ELECTRO-MAGNETIC INTERFERENCE
 - ✓ NEMA MG1 EVALUATION
 - ✓ MOTOR STARTING ABILITY
 - ✓ SHORT CIRCUIT TESTING
 - ✓ UL 2200 COMPLIANCE AVAILABLE
- **SOLID-STATE, FREQUENCY COMPENSATED VOLTAGE REGULATION.** This state-of-the-art power maximizing regulation system is standard on all Generac models. It provides optimized FAST RESPONSE to changing load conditions and MAXIMUM MOTOR STARTING CAPABILITY by electronically torque-matching the surge loads to the engine.
- **SINGLE SOURCE SERVICE RESPONSE** from Generac's dealer network provides parts and service know-how for the entire unit, from the engine to the smallest electronic component. You are never on your own when you own a GENERAC POWER SYSTEM.
- **ECONOMICAL DIESEL POWER.** Low cost operation due to modern diesel engine technology. Better fuel utilization plus lower cost per gallon provide real savings.
- **LONGER ENGINE LIFE.** Generac heavy-duty diesels provide long and reliable operating life.
- **GENERAC TRANSFER SWITCHES, SWITCHGEAR AND ACCESSORIES.** Long life and reliability is synonymous with GENERAC POWER SYSTEMS. One reason for this confidence is that the GENERAC product line includes its own transfer systems, accessories, switchgear and controls for total system compatibility.

GENERAC®

POWER SYSTEMS, INC.

APPLICATION & ENGINEERING DATA

SD230/SD250

GENERATOR SPECIFICATIONS

TYPE	Four-pole, revolving field
ROTOR INSULATION	Class H
STATOR INSULATION	Class H
TOTAL HARMONIC DISTORTION	<3%
TELEPHONE INTERFERENCE FACTOR (TIF)	<50
ALTERNATOR	Self-ventilated and drip-proof
BEARINGS (PRE-LUBED & SEALED)	1
COUPLING	Direct, Flexible Disc
LOAD CAPACITY (STANDBY)	100%
LOAD CAPACITY (PRIME)	110%

NOTE: Emergency loading in compliance with NFPA 99, NFPA 110, paragraph 5-13.2.6. Generator rating and performance in accordance with ISO8528-5, BS5514, SAE J1349, ISO3046 and DIN6271 standards.

EXCITATION SYSTEM

PERMANENT MAGNET EXCITER	Eighteen-pole exciter ✓ Magnetically coupled DC current ✓ Mounted outboard of main bearing ✓
REGULATION	Solid-state ✓ ±1% regulation ✓

GENERATOR FEATURES

- Four pole, revolving field generator, directly connected to the engine shaft through a heavy-duty, flexible disc for permanent alignment.
- Generator meets the temperature rise standards for class "F" insulation as defined by NEMA MG1-32.6, while the insulation system meets the requirements for the higher class "H" rating.
- All prototype models have passed a three-phase symmetrical short circuit test to assure system protection and reliability.
- All prototype models are tested for motor starting ability by measuring the instantaneous voltage dip with a waveform data acquisition system.
- All models utilize an advanced wire harness design for reliable interconnection within the circuitry.
- Magnetic circuit, including amortisseur windings, tooth and skewed stator design, provides a minimal level of waveform distortion and an electromagnetic interference level which meets accepted requirements for standard AM radio, TV, and marine radio telephone applications.
- Voltage waveform deviation, total harmonic content of the AC waveform, and T.I.F. (Telephone Influence Factor) have been evaluated to acceptable standards in accordance with NEMA MG1-32.
- Alternator is self-ventilated and drip-proof constructed.
- Fully life-tested protective systems, including "field circuit and thermal overload protection" and optional main-line circuit breakers capable of handling full output capacity.
- System Torsional acceptability confirmed during Prototype Testing.

ENGINE SPECIFICATIONS

MAKE	GENERAC
MODEL	12.0DTA
CYLINDERS	6 in-line
DISPLACEMENT	11.945 Liter (729 cu. in.)
BORE	130 mm (5.11 in.)
STROKE	150 mm (5.91 in.)
COMPRESSION RATIO	16.5:1
INTAKE AIR	Turbocharged, Aftercooled
NUMBER OF MAIN BEARINGS	7
CONNECTING RODS	6-Carbon Steel
CYLINDER HEAD	(6) 1-Cylinder Cast Iron with Overhead Valve
PISTONS	6-Heat Resistant Aluminum Alloy
CRANKSHAFT	Case Hardened, Die Forged, Carbon Steel

VALVE TRAIN

LIFTER TYPE	Solid
INTAKE VALVE MATERIAL	Special Heat Resistant Steel
EXHAUST VALVE MATERIAL	Sellited Faced Heat Resistant Steel
HARDENED VALVE SEATS	Replaceable

ENGINE GOVERNOR

<input type="checkbox"/> ELECTRONIC	Standard
FREQUENCY REGULATION, NO-LOAD TO FULL LOAD	0.5%
STEADY STATE REGULATION	±0.25%

LUBRICATION SYSTEM

TYPE OF OIL PUMP	Gear
OIL FILTER	Bypass and Full flow, cartridge
CRANKCASE CAPACITY	31 Liters (8.2 U.S. gallons)

COOLING SYSTEM

TYPE OF SYSTEM	Pressurized, closed recovery
WATER PUMP	Pre-lubed, self-sealing
TYPE OF FAN	Pusher
NUMBER OF FAN BLADES	7
DIAMETER OF FAN	762 mm (30 in.)
COOLANT HEATER	120V, 1800W

FUEL SYSTEM

FUEL	#2D Fuel (Min Cetane #40) (Fuel should conform to ASTM Spec.)
FUEL FILTER	10 Micron
FUEL INJECTION PUMP	Bosch PE6P Type
FUEL PUMP	Mechanical
INJECTORS	Multi-hole, nozzle type
ENGINE TYPE	Direct injection
FUEL LINE (Supply)	9.53 mm (0.375 in.)
FUEL RETURN LINE	9.53 mm (0.375 in.)

ELECTRICAL SYSTEM

BATTERY CHARGE ALTERNATOR	35 Amps at 24 V
STARTER MOTOR	24 V
RECOMMENDED BATTERY	(2)—12V, 135 AH
GROUND POLARITY	Negative

Rating definitions - Standby: Applicable for supplying emergency power for the duration of the utility power outage. No overload capability is available for this rating. (All ratings in accordance with BS5514, ISO3046 and DIN6271). Prime (Unlimited Running Time): Applicable for supplying electric power in lieu of commercially purchased power. Prime power is the maximum power available at variable load. A 10% overload capacity is available for 1 hour in 12 hours. (All ratings in accordance with BS5514, ISO3046, ISO8528 and DIN6271).

SD230/SD250

OPERATING DATA

	STANDBY				PRIME			
	SD230		SD250		SD230		SD250	
GENERATOR OUTPUT VOLTAGE/KW-60Hz	Rated AMP		Rated AMP		Rated AMP		Rated AMP	
120/240V, 1-phase, 1.0 pf	150	625	168	700	150	625	168	700
120/208V, 3-phase, 0.8 pf	230	799	250	868	185	643	205	712
120/240V, 3-phase, 0.8 pf	230	692	250	753	185	557	205	617
277/480V, 3-phase, 0.8 pf	230	346	250	376	185	278	205	309
600V, 3-phase, 0.8 pf	230	277	250	301	185	223	205	247
	NOTE: Consult your Generac dealer for additional voltages.							
GENERATOR OUTPUT VOLTAGE/KVA-50Hz	Rated AMP		Rated AMP		Rated AMP		Rated AMP	
110/220V, 1-phase, 1.0 pf	150	682	168	764	150	682	168	764
115/200V, 3-phase, 0.8 pf	230	665	250	723	185	535	205	592
100/200V, 3-phase, 0.8 pf	230	665	250	723	185	535	205	592
231/400V, 3-phase, 0.8 pf	230	332	250	361	185	267	205	296
480V, 3-phase, 0.8 pf	230	277	250	301	185	223	205	247
	NOTE: Consult your Generac dealer for additional voltages.							
MOTOR STARTING KVA								
Maximum at 35% instantaneous voltage dip with standard alternator; 50/60 Hz	240V	480V	240V	480V	240V	480V	240V	480V
with optional alternator; 50/60 Hz	566/680	792/950	566/680	792/950	566/680	792/950	566/680	792/950
	800/960	1116/1340	800/960	1116/1340	800/960	1116/1340	800/960	1116/1340
FUEL	Load		Load		Load		Load	
Fuel consumption—60 Hz gal./hr.	25%	50%	75%	100%	25%	50%	75%	100%
	4.9	9.8	14.7	19.6	5.3	10.7	16.0	21.3
Fuel consumption—50 Hz gal./hr.	3.9	7.8	11.8	15.7	4.3	8.5	12.8	17.1
Fuel pump lift	14.8	29.7	44.6	59.4	16.1	32.3	48.4	64.5
	liters/hr.		liters/hr.		liters/hr.		liters/hr.	
	18.5	37.1	55.7	74.2	20.2	40.4	60.5	80.7
	11.9	23.9	35.8	47.8	13.2	26.5	39.7	52.9
	40"		40"		40"		40"	
COOLING	System - lit. (US gal.)		System - lit. (US gal.)		System - lit. (US gal.)		System - lit. (US gal.)	
Coolant capacity	40	(10.6)	40	(10.6)	40	(10.6)	40	(10.6)
	22	(5.8)	22	(5.8)	22	(5.8)	22	(5.8)
	18	(4.8)	18	(4.8)	18	(4.8)	18	(4.8)
Coolant flow/min.	225	(59.4)	225	(59.4)	225	(59.4)	225	(59.4)
	188	(49.5)	188	(49.5)	188	(49.5)	188	(49.5)
Heat rejection to coolant	BTU/hr.		BTU/hr.		BTU/hr.		BTU/hr.	
Inlet air	686,000		745,500		533,000		612,500	
	493 (17,400)		493 (17,400)		493 (17,400)		493 (17,400)	
	410 (14,500)		410 (14,500)		410 (14,500)		410 (14,500)	
Max. operating air temp. onto radiator*	60 (140)		60 (140)		60 (140)		60 (140)	
Max. operating ambient temp.*	50 (122)		50 (122)		50 (122)		50 (122)	
COMBUSTION AIR REQUIREMENTS	60 Hz - m ³ /min. (cfm)		60 Hz - m ³ /min. (cfm)		60 Hz - m ³ /min. (cfm)		60 Hz - m ³ /min. (cfm)	
Flow at rated power	19.5 (687)		21.0 (743)		15.4 (545)		16.9 (598)	
	16.2 (573)		17.5 (619)		12.9 (454)		14.4 (498)	
EXHAUST	60 Hz - m ³ /min. (cfm)		60 Hz - m ³ /min. (cfm)		60 Hz - m ³ /min. (cfm)		60 Hz - m ³ /min. (cfm)	
Exhaust flow at rated output	54.8 (1936)		59.6 (2105)		44.1 (1557)		48.9 (1726)	
	43.9 (1589)		47.7 (1684)		35.3 (1246)		39.1 (1381)	
Max recommended back pressure	10.0 (3")		10.0 (3")		10.0 (3")		10.0 (3")	
Exhaust temp at rated output	562 (1045)		596 (1105)		518 (965)		538 (1000)	
Exhaust outlet size	5"		5"		5"		5"	
ENGINE	60 Hz / 50 Hz		60 Hz / 50 Hz		60 Hz / 50 Hz		60 Hz / 50 Hz	
Rated RPM	1800 / 1500		1800 / 1500		1800 / 1500		1800 / 1500	
HP at rated KW	325 / 257		354 / 229		263 / 208		287 / 227	
Piston speed	540 (1772)		540 (1772)		540 (1772)		540 (1772)	
	450 (1476)		450 (1476)		450 (1476)		450 (1476)	
BMEP	202 / 162		220 / 176		163 / 130		180 / 144	
POWER ADJUSTMENTS FOR AMBIENT CONDITIONS	-4.5% for every 10°C above - °C		40		40		40	
Temperature	-2.5% for every 10°F above - °F		104		104		104	
Altitude	-0.8% for every 100 m above - m		2293		2293		2293	
	-2.5% for every 1000 ft. above - ft.		7500		7500		7500	

Note: Values given are maximum temperatures to which power adjustments can be applied. Consult your Generac Power Systems representative if operating conditions exceed these maximums.

- High Coolant Temperature Automatic Shutdown
- Low Coolant Level Automatic Shutdown
- Low Oil Pressure Automatic Shutdown
- Overspeed Automatic Shutdown (Solid-state)
- Crank Limiter (Solid-state)
- Oil Drain Extension
- Radiator Drain Extension
- Factory-Installed Cool Flow Radiator
- Closed Coolant Recovery System
- UV/Ozone Resistant Hoses
- Rubber-Booted Engine Electrical Connections
- Secondary Fuel Filter
- Fuel Lockoff Solenoid
- Stainless Steel Flexible Exhaust Connection
- Battery Charge Alternator
- Battery Cables
- Battery Tray
- Vibration Isolation of Unit to Mounting Base
- 24 Volt, Solenoid-activated Starter Motor
- Air Cleaner
- Fan Guard
- Control Console
- Coolant Heater
- Isochronous Governor
- Radiator Duct Adapter

OPTIONS

■ OPTIONAL COOLING SYSTEM ACCESSORIES

- Coolant Heater 208/240 VAC

■ OPTIONAL FUEL ACCESSORIES

- Flexible Fuel Lines
- UL Listed Base Tanks
- Base Tank Low Fuel Alarm
- Primary Fuel Filters

■ OPTIONAL EXHAUST ACCESSORIES

- Critical Exhaust Silencer (Standard on enclosed gensets)

■ OPTIONAL ELECTRICAL ACCESSORIES

- Battery, 12 Volt, 135 A.H., 4D (2 req'd)
- Battery, 12 Volt, 225 A.H., 8D (2 req'd)
- 2A Battery Charger
- 10A Dual Rate Battery Charger
- Battery Heater

■ OPTIONAL ALTERNATOR ACCESSORIES

- Alternator Upsizing
- Alternator Strip Heater
- Alternator Tropicalization
- Main Line Circuit Breaker

■ CONTROL CONSOLE OPTIONS

- Analog Control "C" Panel (Bulletin 0151160SBY)
- Analog / Digital Control Panel (Bulletin 0161310SBY)

■ ADDITIONAL OPTIONAL EQUIPMENT

- Automatic Transfer Switch
- 3 Light Remote Annunciator
- 5 Light Remote Annunciator
- 20 Light Remote Annunciator
- Remote Relay Panels
- Unit Vibration Isolators
- Oil Make-Up System
- Oil Heater
- 5 Year Warranties
- Export Boxing
- GenLink® Communications Software

■ OPTIONAL ENCLOSURES

- Weather Protective
- Sound Attenuated
- Aluminum and Stainless Steel
- Enclosed Muffler

Distributed by:

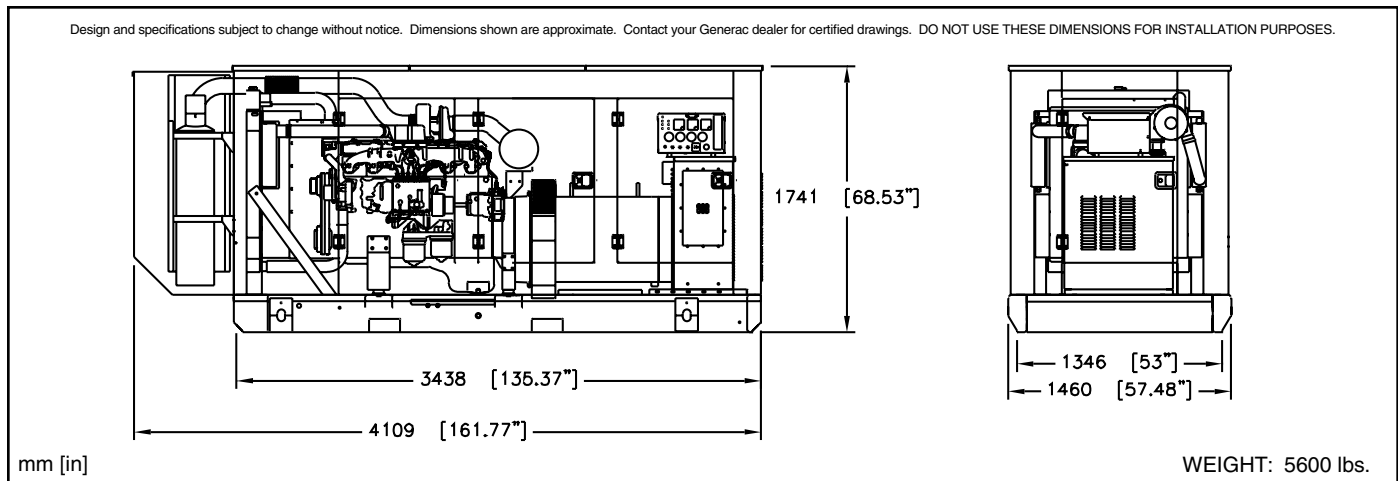

GENERAC® POWER SYSTEMS, INC. • P.O. BOX 8 • WAUKESHA, WI 53187

262/544-4811 • FAX 262/544-4851