

SD275 SD300

Liquid Cooled Diesel Engine Generator Sets

Standby Power Rating

275KW 60 Hz / 275KVA 50 Hz

300KW 60 Hz / 300KVA 50 Hz

Prime Power Rating

233KW 60 Hz /233KVA 50 Hz

245KW 60 Hz /245KVA 50 Hz

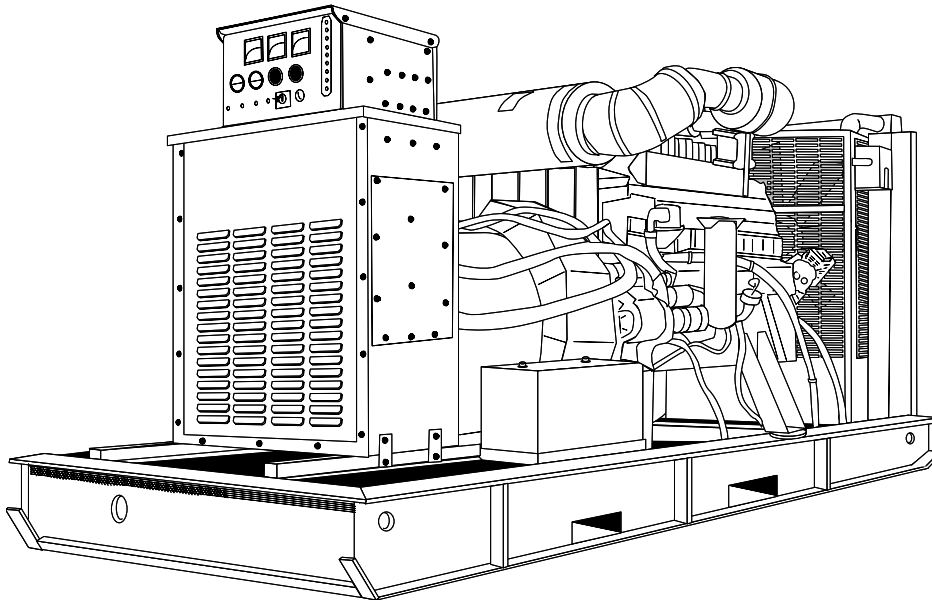

Power Matched

GENERAC 12.0DTA ENGINE

Turbocharged, Aftercooled

FEATURES

- **INNOVATIVE DESIGN & PROTOTYPE TESTING** are key components of GENERAC'S success in "IMPROVING POWER BY DESIGN." But it doesn't stop there. Total commitment to component testing, reliability testing, environmental testing, destruction and life testing, plus testing to applicable CSA, NEMA, EGSA, and other standards, allows you to choose GENERAC POWER SYSTEMS with the confidence that these systems will provide superior performance.
- **TEST CRITERIA:**
 - ✓ PROTOTYPE TESTED
 - ✓ SYSTEM TORSIONAL TESTED
 - ✓ ELECTRO-MAGNETIC INTERFERENCE
 - ✓ NEMA MG1 EVALUATION
 - ✓ MOTOR STARTING ABILITY
 - ✓ SHORT CIRCUIT TESTING
 - ✓ UL 2200 COMPLIANCE AVAILABLE
- **SOLID-STATE, FREQUENCY COMPENSATED VOLTAGE REGULATION.** This state-of-the-art power maximizing regulation system is standard on all Generac models. It provides optimized FAST RESPONSE to changing load conditions and MAXIMUM MOTOR STARTING CAPABILITY by electronically torque-matching the surge loads to the engine.
- **SINGLE SOURCE SERVICE RESPONSE** from Generac's dealer network provides parts and service know-how for the entire unit, from the engine to the smallest electronic component. You are never on your own when you own a GENERAC POWER SYSTEM.
- **ECONOMICAL DIESEL POWER.** Low cost operation due to modern diesel engine technology. Better fuel utilization plus lower cost per gallon provide real savings.
- **LONGER ENGINE LIFE.** Generac heavy-duty diesels provide long and reliable operating life.
- **GENERAC TRANSFER SWITCHES, SWITCHGEAR AND ACCESSORIES.** Long life and reliability is synonymous with GENERAC POWER SYSTEMS. One reason for this confidence is that the GENERAC product line includes its own transfer systems, accessories, switchgear and controls for total system compatibility.

GENERAC®

POWER SYSTEMS, INC.

GENERATOR SPECIFICATIONS

TYPE	Four-pole, revolving field
ROTOR INSULATION	Class H
STATOR INSULATION	Class H
TOTAL HARMONIC DISTORTION	<3%
TELEPHONE INTERFERENCE FACTOR (TIF)	<50
ALTERNATOR	Self-ventilated and drip-proof
BEARINGS (PRE-LUBED & SEALED)	1
COUPLING	Direct, Flexible Disc
LOAD CAPACITY (STANDBY)	100%
LOAD CAPACITY (PRIME)	110%

NOTE: Emergency loading in compliance with NFPA 99, NFPA 110, paragraph 5-13.2.6. Generator rating and performance in accordance with ISO8528-5, BS5514, SAE J1349, ISO3046 and DIN6271 standards.

EXCITATION SYSTEM

PERMANENT MAGNET EXCITER	Eighteen-pole exciter ✓
	Magnetically coupled DC current ✓
	Mounted outboard of main bearing ✓
REGULATION	Solid-state ✓
	±1% regulation ✓

GENERATOR FEATURES

- Four pole, revolving field generator, directly connected to the engine shaft through a heavy-duty, flexible disc for permanent alignment.
- Generator meets the temperature rise standards for class "F" insulation as defined by NEMA MG1-32.6, while the insulation system meets the requirements for the higher class "H" rating.
- All prototype models have passed a three-phase symmetrical short circuit test to assure system protection and reliability.
- All prototype models are tested for motor starting ability by measuring the instantaneous voltage dip with a waveform data acquisition system.
- All models utilize an advanced wire harness design for reliable interconnection within the circuitry.
- Magnetic circuit, including amortisseur windings, tooth and skewed stator design, provides a minimal level of waveform distortion and an electromagnetic interference level which meets accepted requirements for standard AM radio, TV, and marine radio telephone applications.
- Voltage waveform deviation, total harmonic content of the AC waveform, and T.I.F. (Telephone Influence Factor) have been evaluated to acceptable standards in accordance with NEMA MG1-32.
- Alternator is self-ventilated and drip-proof constructed.
- Fully life-tested protective systems, including "field circuit and thermal overload protection" and optional main-line circuit breakers capable of handling full output capacity.
- System Torsional acceptability confirmed during Prototype Testing.

ENGINE SPECIFICATIONS

MAKE	GENERAC
MODEL	12.0DTA
CYLINDERS	6 in-line
DISPLACEMENT	11.945 Liter (729 cu. in.)
BORE	130 mm (5.11 in.)
STROKE	150 mm (5.91 in.)
COMPRESSION RATIO	16.5:1
INTAKE AIR	Turbocharged, Aftercooled
NUMBER OF MAIN BEARINGS	7
CONNECTING RODS	6-Carbon Steel
CYLINDER HEAD	(6) 1-Cylinder Cast Iron with Overhead Valve
PISTONS	6-Heat Resistant Aluminum Alloy
CRANKSHAFT	Case Hardened, Die Forged, Carbon Steel

VALVE TRAIN

LIFTER TYPE	Solid
INTAKE VALVE MATERIAL	Special Heat Resistant Steel
EXHAUST VALVE MATERIAL	Sellited Faced Heat Resistant Steel
HARDENED VALVE SEATS	Replaceable

ENGINE GOVERNOR

<input type="checkbox"/> ELECTRONIC	Standard
FREQUENCY REGULATION, NO-LOAD TO FULL LOAD	0.5%
STEADY STATE REGULATION	±0.25%

LUBRICATION SYSTEM

TYPE OF OIL PUMP	Gear
OIL FILTER	Bypass and Full flow, cartridge
CRANKCASE CAPACITY	31 Liters (8.2 U.S. gal.)

COOLING SYSTEM

TYPE OF SYSTEM	Pressurized, closed recovery
WATER PUMP	Pre-lubed, self-sealing
NUMBER OF FAN	Pusher
TYPE OF FAN BLADES	7
DIAMETER OF FAN	762 mm (30 in.)
COOLANT HEATER SD300	240V, 2000W
SD275	120V, 1800W

FUEL SYSTEM

FUEL	#2D Fuel (Min Cetane #40) (Fuel should conform to ASTM Spec.)
FUEL FILTER	10 Micron
FUEL INJECTION PUMP	Bosch PE6P Type
FUEL PUMP	Mechanical
INJECTORS	Multi-hole, nozzle type
ENGINE TYPE	Direct injection
FUEL LINE (Supply)	9.53 mm (0.375 in.)
FUEL RETURN LINE	9.53 mm (0.375 in.)

ELECTRICAL SYSTEM

BATTERY CHARGE ALTERNATOR	35 Amps at 24 V
STARTER MOTOR	24 V
RECOMMENDED BATTERY	(2)—12V, 135 AH
GROUND POLARITY	Negative

SD275/SD300

OPERATING DATA

	STANDBY				PRIME			
	SD275		SD300		SD275		SD300	
GENERATOR OUTPUT VOLTAGE/KW-60Hz	<u>Rated AMP</u>		<u>Rated AMP</u>		<u>Rated AMP</u>		<u>Rated AMP</u>	
120/240V, 1-phase, 1.0 pf	180	750	200	833	180	750	200	833
120/208V, 3-phase, 0.8 pf	275	955	300	1042	233	809	245	851
120/240V, 3-phase, 0.8 pf	275	828	300	903	233	701	245	738
277/480V, 3-phase, 0.8 pf	275	414	300	452	233	351	245	369
600V, 3-phase, 0.8 pf	275	331	300	361	233	281	245	295
	NOTE: Consult your Generac dealer for additional voltages.							
GENERATOR OUTPUT VOLTAGE/KVA-50Hz	<u>Rated AMP</u>		<u>Rated AMP</u>		<u>Rated AMP</u>		<u>Rated AMP</u>	
110/220V, 1-phase, 1.0 pf	145	659	200	909	145	659	200	909
115/200V, 3-phase, 0.8 pf	275	795	300	867	233	673	245	708
100/200V, 3-phase, 0.8 pf	275	795	300	867	233	673	245	708
231/400V, 3-phase, 0.8 pf	275	397	300	434	233	337	245	354
480V, 3-phase, 0.8 pf	275	331	300	361	233	281	245	295
	NOTE: Consult your Generac dealer for additional voltages.							
MOTOR STARTING KVA								
Maximum at 35% instantaneous voltage dip with standard alternator; 50/60 Hz	<u>231/240V</u>	<u>400/480V</u>	<u>231/240V</u>	<u>400/480V</u>	<u>231/240V</u>	<u>400/480V</u>	<u>231/240V</u>	<u>400/480V</u>
with optional alternator; 50/60 Hz	654/785	910/1092	654/785	910/1092	654/785	910/1092	654/785	910/1092
	800/960	1116/1340	800/960	1116/1340	800/960	1116/1340	800/960	1116/1340
FUEL								
Fuel consumption—60 Hz	25%	50%	75%	100%	25%	50%	75%	100%
Load gal./hr.	5.9	11.7	17.6	23.5	6.4	12.8	19.2	25.6
liters/hr.	22.2	44.4	66.6	88.8	24.2	48.4	72.6	96.8
Fuel consumption—50 Hz	25%	50%	75%	100%	25%	50%	75%	100%
gal./hr.	4.7	9.4	14.1	18.8	5.1	10.2	15.4	20.5
liters/hr.	17.8	35.5	53.3	71.0	19.4	38.7	58.1	77.4
Fuel pump lift	40"		40"		40"		40"	
COOLING								
Coolant capacity	System - lit. (US gal.)		40 (10.6)		40 (10.6)		40 (10.6)	
	Engine - lit. (US gal.)		22 (5.8)		22 (5.8)		22 (5.8)	
	Radiator - lit. (US gal.)		18 (4.8)		18 (4.8)		18 (4.8)	
Coolant flow/min.	60 Hz - lit. (US gal.)		225 (59.4)		225 (59.4)		225 (59.4)	
	50 Hz - lit. (US gal.)		188 (49.5)		188 (49.5)		188 (49.5)	
Heat rejection to coolant	BTU/hr.		821,000		895,000		695,500	
Inlet air	60 Hz - m ³ /min. (cfm)		493 (17,400)		493 (17,400)		493 (17,400)	
	50 Hz - m ³ /min. (cfm)		410 (14,500)		410 (14,500)		410 (14,500)	
Max. operating air temp. onto radiator *see note	°C (°F)		60 (140)		60 (140)		60 (140)	
Max. operating ambient temp *see note	°C (°F)		50 (122)		50 (122)		50 (122)	
COMBUSTION AIR REQUIREMENTS								
Flow at rated power	60 Hz - m ³ /min. (cfm)		23.0 (813)		25.1 (886)		19.5 (688)	
	50 Hz - m ³ /min. (cfm)		19.2 (678)		20.9 (738)		16.2 (573)	
EXHAUST								
Exhaust flow at rated output	60 Hz - m ³ /min. (cfm)		67.5 (2383)		70.6 (2494)		61.2 (2160)	
	50 Hz - m ³ /min. (cfm)		56.2 (1986)		58.8 (2078)		51.0 (1800)	
Max recommended back pressure	Kpa (Hg)		10.0 (3")		10.0 (3")		10.0 (3")	
Exhaust temperature at rated output	°C (°F)		676 (1250)		721 (1330)		588 (1090)	
Exhaust outlet size	5"		5"		5"		5"	
ENGINE								
Rated RPM	60 Hz / 50 Hz		1800 / 1500		1800 / 1500		1800 / 1500	
HP at rated KW	60 Hz / 50 Hz		393 / 310		427 / 337		319 / 252	
Piston speed	60 Hz - m/min. (ft./min.)		540 (1772)		540 (1772)		540 (1772)	
	50 Hz - m/min. (ft./min.)		450 (1476)		450 (1476)		450 (1476)	
BMEP	60 Hz / 50 Hz - psi		242 / 232		264 / 253		205 / 197	
POWER ADJUSTMENTS FOR AMBIENT CONDITIONS								
Temperature	-4.5% for every 10°C above - °C		40		40		40	
	-2.5% for every 10°F above - °F		104		104		104	
Altitude	0.8% for every 100 m above - m		1070		1070		760	
	2.5% for every 1000 ft. above - ft.		3500		3500		2500	

*Note: Values given are maximum temperatures to which power adjustments can be applied. Consult your Generac Power Systems representative if operating conditions exceed these maximums.

STANDARD ENGINE & SAFETY FEATURES

SD275/SD300

- High Coolant Temperature Automatic Shutdown
- Low Coolant Level Automatic Shutdown
- Low Oil Pressure Automatic Shutdown
- Overspeed Automatic Shutdown (Solid-state)
- Crank Limiter (Solid-state)
- Oil Drain Extension
- Radiator Drain Extension
- Factory-Installed Cool Flow Radiator
- Closed Coolant Recovery System
- UV/Ozone Resistant Hoses
- Rubber-Booted Engine Electrical Connections
- Secondary Fuel Filter
- Fuel Lockoff Solenoid

- Stainless Steel Flexible Exhaust Connection
- Battery Charge Alternator
- Battery Cables
- Battery Tray
- Vibration Isolation of Unit to Mounting Base
- 24 Volt, Solenoid-activated Starter Motor
- Air Cleaner
- Fan Guard
- Control Console
- Coolant Heater
- Isochronous Governor
- Radiator Duct Adapter

OPTIONS

■ OPTIONAL COOLING SYSTEM ACCESSORIES

- Coolant Heater 208/240

■ OPTIONAL FUEL ACCESSORIES

- Flexible Fuel Lines
- UL Listed Base Tank
- Base Tank Low Fuel Alarm
- Primary Fuel Filters

■ OPTIONAL EXHAUST ACCESSORIES

- Critical Exhaust Silencer (Standard on enclosed genset)

■ OPTIONAL ELECTRICAL ACCESSORIES

- Battery, 12 Volt, 135 A.H., 4D (2 req'd)
- Battery, 12 Volt, 225 A.H., 8D (2 req'd)
- 2A Battery Charger
- 10A Dual Rate Battery Charger
- Battery Heater

■ OPTIONAL ALTERNATOR ACCESSORIES

- Alternator Upsizing
- Alternator Strip Heater
- Alternator Tropicalization
- Main Line Circuit Breaker

■ CONTROL CONSOLE OPTIONS

- Analog Control "C" Panel (Bulletin 0151160SBY)
- Analog / Digital Control Panel (Bulletin 0161310SBY)

■ ADDITIONAL OPTIONAL EQUIPMENT

- Automatic Transfer Switch
- 3 Light Remote Annunciator
- 5 Light Remote Annunciator
- 20 Light Remote Annunciator
- Remote Relay Panel
- Unit Vibration Isolators
- Oil Make-Up System
- Oil Heater
- 5 Year Warranties
- Export Boxing
- GenLink® Communications Software

■ OPTIONAL ENCLOSURES

- Weather Protective
- Sound Attenuated
- Aluminum and Stainless Steel
- Enclosed Muffler

Distributed by:

Design and specifications subject to change without notice. Dimensions shown are approximate. Contact your Generac dealer for certified drawings. DO NOT USE THESE DIMENSIONS FOR INSTALLATION PURPOSES.

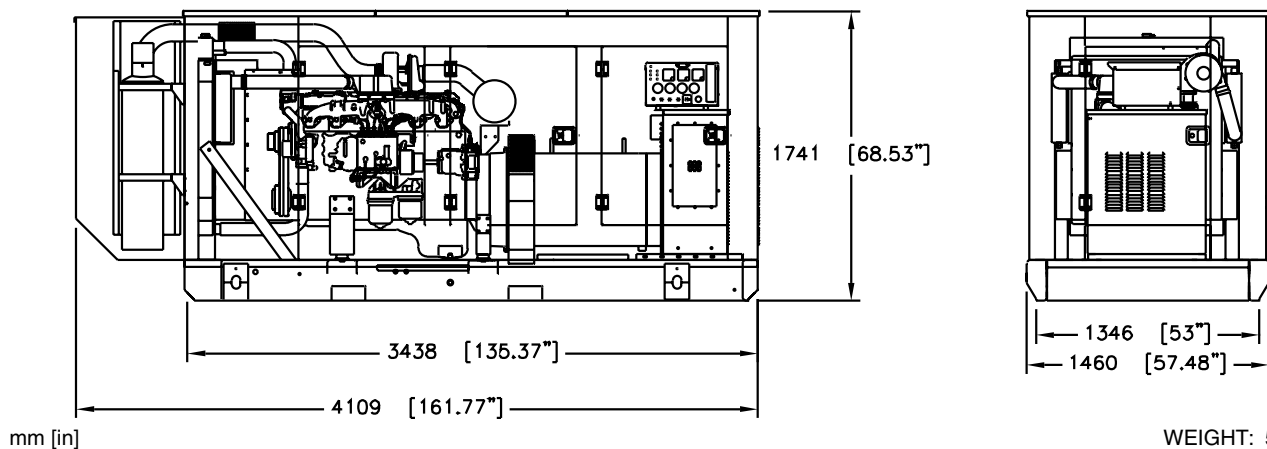

WEIGHT: 5600 lbs.

GENERAC® POWER SYSTEMS, INC. • P.O. BOX 8 • WAUKESHA, WI 53187

262/544-4811 • FAX 262/544-4851