

# SD050

## Liquid Cooled Diesel Engine Generator Sets

Standby Power Rating  
50KW 60 Hz / 50KVA 50 Hz

Prime Power Rating  
44KW 60 Hz / 44KVA 50 Hz

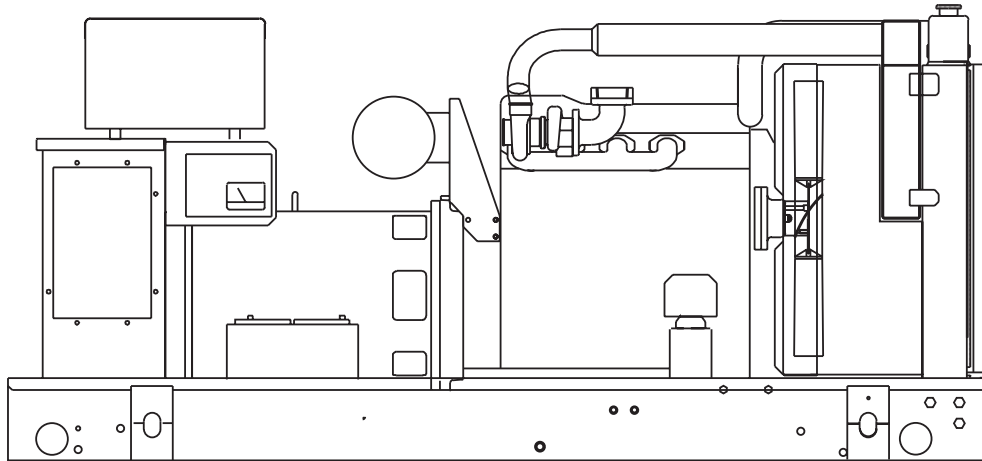

Power Matched  
**GENERAC 2.4DTA ENGINE**  
Turbocharged/Aftercooled  
Tier III Compliant

## FEATURES

- **INNOVATIVE DESIGN & PROTOTYPE TESTING** are key components of GENERAC'S success in "IMPROVING POWER BY DESIGN." But it doesn't stop there. Total commitment to component testing, reliability testing, environmental testing, destruction and life testing, plus testing to applicable CSA, NEMA, EGSA, and other standards, allows you to choose GENERAC POWER SYSTEMS with the confidence that these systems will provide superior performance.
- **TEST CRITERIA:**
  - ✓ PROTOTYPE TESTED
  - ✓ SYSTEM TORSIONAL TESTED
  - ✓ ELECTRO-MAGNETIC INTERFERENCE
  - ✓ NEMA MG1 EVALUATION
  - ✓ MOTOR STARTING ABILITY
  - ✓ SHORT CIRCUIT TESTING
  - ✓ UL COMPLIANCE AVAILABLE
- **SOLID-STATE, FREQUENCY COMPENSATED DIGITAL VOLTAGE REGULATION.** This state-of-the-art power maximizing regulation system is standard on all Generac models. It provides optimized FAST RESPONSE to changing load conditions and MAXIMUM MOTOR STARTING CAPABILITY by electronically torque-matching the surge loads to the engine.
- **SINGLE SOURCE SERVICE RESPONSE** from Generac's dealer network provides parts and service know-how for the entire unit, from the engine to the smallest electronic component. You are never on your own when you own a GENERAC POWER SYSTEM.
- **ECONOMICAL DIESEL POWER.** Low cost operation due to modern diesel engine technology. Better fuel utilization plus lower cost per gallon provide real savings.
- **LONGER ENGINE LIFE.** Generac heavy-duty diesels provide long and reliable operating life.
- **GENERAC TRANSFER SWITCHES, SWITCHGEAR AND ACCESSORIES.** Long life and reliability is synonymous with GENERAC POWER SYSTEMS. One reason for this confidence is that the GENERAC product line includes its own transfer systems, accessories, switchgear and controls for total system compatibility.

# GENERAC®

# APPLICATION & ENGINEERING DATA

SD050

## GENERATOR SPECIFICATIONS

TYPE .....	Four-pole, revolving field
ROTOR INSULATION .....	Class H
STATOR INSULATION .....	Class H
TOTAL HARMONIC DISTORTION .....	<3%
TELEPHONE INTERFERENCE FACTOR (TIF) .....	<50
ALTERNATOR .....	Self-ventilated and drip-proof
BEARINGS (PRE-LUBED & SEALED) .....	1
COUPLING .....	Direct, Flexible Disc
LOAD CAPACITY (STANDBY) .....	100%
LOAD CAPACITY (PRIME) .....	110%

**NOTE: Emergency loading in compliance with NFPA 99, NFPA 110. Generator rating and performance in accordance with ISO8528-5, BS5514, SAE J1349, ISO3046 and DIN6271 standards.**

## VOLTAGE REGULATOR

TYPE .....	Full Digital
SENSING .....	3 Phase
REGULATION .....	± 1/4%
FEATURES .....	Built into H-100 Control Panel, V/F Adjustable Adjustable Voltage and Gain

## GENERATOR FEATURES

- Revolving field heavy duty generator
- Quiet drive coupling
- Operating temperature rise 120°C above a 40°C ambient
- Insulation is Class H rated at 150°C rise
- All prototype models have passed three phase short circuit testing

## CONTROL PANEL FEATURES

- TWO FOUR LINE LCD DISPLAYS READ:
  - Voltage (all phases)
  - Power factor
  - kVAR
  - Engine speed
  - Run hours
  - Fault history
  - Coolant temperature
  - Low oil pressure shutdown
  - Overvoltage
  - Low coolant level
  - Exercise speed
  - Not in auto position (flashing light)
  - Current (all phases)
  - kW
  - Transfer switch status
  - Low fuel pressure
  - Service reminders
  - Oil pressure
  - Time and date
  - High coolant temp shutdown
  - Overspeed
  - Low coolant level
  - ATS selection
- INTERNAL FUNCTIONS:
  - I<sup>2</sup>T function for alternator protection from line to neutral and line to line short circuits
  - Emergency stop
  - Programmable auto crank function
  - 2 wire start for any transfer switch
  - Communicates with the Generac HTS transfer switch
  - Built-in 7 day exerciser
  - Adjustable engine speed at exerciser
  - RS232 port for GenLink® control
  - RS485 port remote communication
  - Canbus addressable
  - Governor controller and voltage regulator are built into the master control board
  - Temperature range -40°C to 70°C

## ENGINE SPECIFICATIONS

MAKE .....	GENERAC/DEERE
MODEL .....	See Exhaust Emission Sheet
ENGINE FAMILY .....	First digit is Cert. Yr. (i.e. 7, 8, 9) _JDXL03.0113
CYLINDERS .....	4
DISPLACEMENT .....	2.4 Liter (149 cu.in.)
BORE .....	86 mm (3.4 in.)
STROKE .....	105 mm (4.1 in.)
COMPRESSION RATIO .....	18:1
INTAKE AIR .....	Turbocharged/Aftercooled
NUMBER OF MAIN BEARINGS .....	5
CONNECTING RODS .....	4-Drop Forged Steel
CYLINDER HEAD .....	Cast Iron
PISTONS .....	4-Aluminum Alloy
CRANKSHAFT .....	Die Forged, Induction Hardened Steel

### VALVE TRAIN

LIFTER TYPE .....	Solid
INTAKE VALVE MATERIAL .....	Heat Resistant Steel
EXHAUST VALVE MATERIAL .....	Heat Resistant Steel
HARDENED VALVE SEATS .....	Replaceable

### ENGINE GOVERNOR

<input type="checkbox"/> ELECTRONIC .....	Standard
FREQUENCY REGULATION, NO-LOAD TO FULL LOAD .....	Isochronous
STEADY STATE REGULATION .....	±0.25%

### LUBRICATION SYSTEM

TYPE OF OIL PUMP .....	Gear
OIL FILTER .....	Full flow, Cartridge
CRANKCASE CAPACITY .....	7.5 qts.

### COOLING SYSTEM

TYPE OF SYSTEM .....	Pressurized, Closed Recovery
WATER PUMP .....	Pre-Lubed, Self-Sealing
TYPE OF FAN .....	Pusher
NUMBER OF FAN BLADES .....	6
DIAMETER OF FAN .....	560 mm (22 in.)
COOLANT HEATER .....	120V, 1000 W

### FUEL SYSTEM

FUEL .....	#2D Fuel (Min Cetane #40) (Fuel should conform to ASTM Spec.)
FUEL FILTER .....	5 Micron
FUEL INJECTION PUMP .....	Bosch
FUEL PUMP .....	Mechanical
INJECTORS .....	Unit Type Multi-Hole, Nozzle
ENGINE TYPE .....	Pre-combustion
FUEL LINE (Supply) .....	6.35 mm (0.25 in.)
FUEL RETURN LINE .....	6.35 mm (0.25 in.)

### ELECTRICAL SYSTEM

BATTERY CHARGE ALTERNATOR .....	20 Amps at 12 V
STARTER MOTOR .....	12 V
RECOMMENDED BATTERY .....	12 Volt, 90 A.H., 27F
GROUND POLARITY .....	Negative

Rating definitions - Standby: Applicable for supplying emergency power for the duration of the utility power outage. No overload capability is available for this rating. (All ratings in accordance with BS5514, ISO3046 and DIN6271). Prime (Unlimited Running Time): Applicable for supplying electric power in lieu of commercially purchased power. Prime power is the maximum power available at variable load. A 10% overload capacity is available for 1 hour in 12 hours. (All ratings in accordance with BS5514, ISO3046, ISO8528 and DIN6271).

## OPERATING DATA

	<b>STANDBY</b>				<b>PRIME</b>				
	<b>SD050</b>				<b>SD050</b>				
<b>GENERATOR OUTPUT VOLTAGE/KW-60Hz</b>	<b>Rated AMP</b>				<b>Rated AMP</b>				
120/240V, 1-phase, 1.0 pf	50			208	44			183	
120/208V, 3-phase, 0.8 pf	50			173	44			153	
120/240V, 3-phase, 0.8 pf	50			150	44			133	
277/480V, 3-phase, 0.8 pf	50			75	44			66	
600V, 3-phase, 0.8 pf	50			60	44			53	
	NOTE: Consult your Generac dealer for additional voltages.								
<b>GENERATOR OUTPUT VOLTAGE/KVA-50Hz</b>	<b>Rated AMP</b>				<b>Rated AMP</b>				
110/220V, 1-phase, 1.0 pf	40			182	35			159	
115/200V, 3-phase, 0.8 pf	50			144	44			127	
100/200V, 3-phase, 0.8 pf	50			144	44			127	
231/400V, 3-phase, 0.8 pf	50			72	44			63	
	NOTE: Consult your Generac dealer for additional voltage								
<b>MOTOR STARTING KVA</b>									
Maximum at 35% instantaneous voltage dip with standard alternator; 50/60 Hz	<b>208/240/416V</b>		<b>480V</b>		<b>208/240/416V</b>		<b>480V</b>		
	75/90		100/120		75/90		100/120		
<b>FUEL</b>									
Fuel consumption—60 Hz	Load	<b>25%</b>	<b>50%</b>	<b>75%</b>	<b>100%</b>	<b>25%</b>	<b>50%</b>	<b>75%</b>	<b>100%</b>
	gal./hr.	1.12	2.19	3.21	4.16	0.99	1.93	2.82	3.66
	liters/hr.	4.25	8.3	12.13	15.76	3.74	7.3	10.68	13.87
Fuel consumption—50 Hz	gal./hr.	0.9	1.75	2.56	3.33	0.79	1.54	2.26	2.93
Fuel pump lift	liters/hr.	3.4	6.64	9.71	12.61	2.99	5.84	8.54	11.1
		40"				40"			
<b>COOLING</b>									
Coolant capacity	System - US gal. (lit.)	4.5 (17.0)				4.5 (17.0)			
	Engine - US gal. (lit.)	2.75 (10.4)				2.75 (10.4)			
Coolant flow/min.	60 Hz - US gal. (lit.)	28 (106)				28 (106)			
	50 Hz - US gal. (lit.)	23 (87)				23 (87)			
Heat rejection to coolant 60 Hz full load	BTU/hr.	135,900				109,000			
Heat rejection to coolant 50 Hz full load	BTU/hr.	115,500				92,600			
Inlet air	60 Hz - cfm (m³/min.)	7500 (212.4)				7500 (212.4)			
	50 Hz - cfm (m³/min.)	6225 (176.3)				6225 (176.3)			
Max. air temperature to radiator	°C (°F)	60 (140)				60 (140)			
Max. ambient temperature	°C (°F)	50 (122)				50 (122)			
<b>COMBUSTION AIR REQUIREMENTS</b>									
Flow at rated power	60 Hz - cfm (m³/min.)	166 (4.7)				140 (4.0)			
	50 Hz - cfm (m³/min.)	140 (4.0)				120 (3.4)			
<b>EXHAUST</b>									
Exhaust flow at rated output 60 Hz - cfm (m³/min.)	448 (12.7)				380 (10.8)				
	50 Hz - cfm (m³/min.)				320 (9.1)				
Max recommended back pressure	Inches Hg	2.2				2.2			
Exhaust temperature 60 Hz (full load)	°F (°C)	1044 (562)				925 (496)			
Exhaust outlet size	2.5" O.D. Turbo				2.5" O.D. Muffler				
<b>ENGINE</b>									
Rated RPM	60 Hz / 50 Hz	1800 / 1500				1800			
HP at rated KW	60 Hz / 50 Hz	79 / 64				64 / 52			
Piston speed	60 Hz - ft./min. (m/min.)	1536 (1230)				1536 (1230)			
	50 Hz - ft./min. (m/min.)	1279 (1025)				1279 (1025)			
BMEP	60 Hz / 50 Hz - psi	189 / 181				151 / 147			
<b>DERATION FACTORS</b>									
Temperature									
	6.7% for every 10°C above - °C	25				25			
	4.0% for every 10°F above - °F	77				77			
Altitude									
	0.8% for every 100 m above - m	1067				1067			
	2.6% for every 1000 ft. above - ft.	3500				3500			

- High Coolant Temperature Automatic Shutdown
- Low Coolant Level Automatic Shutdown
- Low Oil Pressure Automatic Shutdown
- Overspeed Automatic Shutdown (Solid-state)
- Crank Limiter (Solid-state)
- Oil Drain Extension
- Radiator Drain Extension
- Factory-Installed Cool Flow Radiator
- Closed Coolant Recovery System
- UV/Ozone Resistant Hoses
- Rubber-Booted Engine Electrical Connections
- Coolant Heater
- Secondary Fuel Filter

- Fuel Lockoff Solenoid
- Stainless Steel Flexible Exhaust Connection
- Battery Charge Alternator
- Battery Cables
- Battery Tray
- Vibration Isolation of Unit to Mounting Base
- 12 Volt, Solenoid-activated Starter Motor
- Air Cleaner
- Fan Guard
- Control Console
- Radiator Duct Adaptor
- Ischronous Governor

## OPTIONS

### ■ OPTIONAL COOLING SYSTEM ACCESSORIES

- 208/240V Coolant Heater

### ■ OPTIONAL FUEL ACCESSORIES

- Flexible Fuel Lines
- UL Listed Fuel Tanks
- Base Tank Low Fuel Alarm
- Primary Fuel Filters

### ■ OPTIONAL EXHAUST ACCESSORIES

- Critical Exhaust Silencer

### ■ OPTIONAL ELECTRICAL ACCESSORIES

- 2A Battery Charger
- 10A Dual Rate Battery Charger
- Battery, 12 Volt, 135 A.H.

### ■ OPTIONAL ALTERNATOR ACCESSORIES

- Alternator Upsizing
- Alternator Strip Heater
- Alternator Tropicalization
- Voltage Changeover Switch
- Main Line Circuit Breaker

### ■ CONTROL CONSOLE OPTIONS

- Digital Controller H100 (Bulletin 0172110SBY)

### ■ ADDITIONAL OPTIONAL EQUIPMENT

- Automatic Transfer Switch
- Remote Relay Panels
- Unit Vibration Isolators
- Oil Make-Up System
- Oil Heater
- 5 Year Warranties
- Export Boxing
- GenLink® Communications Software

### ■ OPTIONAL ENCLOSURE

- Weather Protective
- Sound Attenuated
- Aluminum and Stainless Steel
- Enclosed Muffler

**Distributed by:**

