



GENERAC® GUARDIAN® SERIES STANDBY GENERATORS

www.onsitepowergenerators.com

30 kW

Liquid-Cooled Engine Generator Sets

Standby Power Rating

Model QT030 (Bisque) - 30 kW 60Hz

INCLUDES:

- Generac Naturally Aspirated Gaseous Fueled 1.6L Engine
- Two Line LCD Tri-lingual Digital Nexus™ Controller
- Isochronous Electronic Governor
- Closed Coolant Recovery System
- Smart Battery Charger
- UV/Ozone Resistant Hoses
- ±1% Voltage Regulation
- Natural Gas or LP Operation
- UL 2200 Listed



QUIET-TEST™

Meets EPA Emission Regulations

FEATURES

- **INNOVATIVE DESIGN & PROTOTYPE TESTING** are key components of GENERAC'S success in "IMPROVING POWER BY DESIGN." But it doesn't stop there. Total commitment to component testing, reliability testing, environmental testing, destruction and life testing, plus testing to applicable CSA, NEMA, EGSA, and other standards, allows you to choose GENERAC POWER SYSTEMS with the confidence that these systems will provide superior performance.
- **TEST CRITERIA:**
 - ✓ PROTOTYPE TESTED
 - ✓ NEMA MG1-22 EVALUATION
 - ✓ SYSTEM TORSIONAL TESTED
 - ✓ MOTOR STARTING ABILITY
- **SOLID-STATE, FREQUENCY COMPENSATED VOLTAGE REGULATION.** This state-of-the-art power maximizing regulation system is standard on all Generac models. It provides optimized FAST RESPONSE to changing load conditions and MAXIMUM MOTOR STARTING CAPABILITY by electronically torque-matching the surge loads to the engine. An unequalled ±1% voltage regulation.
- **SINGLE SOURCE SERVICE RESPONSE** from Generac's extensive dealer network provides parts and service know-how for the entire unit, from the engine to the smallest electronic component.
- **GENERAC TRANSFER SWITCHES.** Long life and reliability are synonymous with GENERAC POWER SYSTEMS. One reason for this confidence is that the GENERAC product line includes its own transfer systems and controls for total system compatibility.

GENERAC®

GENERATOR SPECIFICATIONS

TYPE	Synchronous
ROTOR INSULATION	Class F
STATOR INSULATION	Class F
TELEPHONE INTERFERENCE FACTOR (TIF)	< 50
ALTERNATOR OUTPUT LEADS 3 PHASE	4 wire
BEARINGS	Sealed Ball
COUPLING	Flexible Disc
LOAD CAPACITY (STANDBY RATING)	30 kW
EXCITATION SYSTEM	Direct

VOLTAGE REGULATION

TYPE	Electronic
SENSING	Single Phase
REGULATION	± 1%

GENERATOR FEATURES

Revolving field heavy duty generator
 Directly connected to the engine
 Operating temperature rise 120 °C above a 40 °C ambient
 Insulation is Class F rated at 130 °C rise
 All models are fully prototyped tested

ENCLOSURE FEATURES

Galvanized steel weather protective enclosure	Ensures protection against mother nature. Electrostatically applied textured epoxy paint for added durability.
Enclosed critical grade muffler	Quiet, critical grade muffler is mounted inside the unit to prevent injuries.
Small, compact, attractive	Makes for an easy, eye appealing installation.

ENGINE SPECIFICATIONS

MAKE	Generac
MODEL	In line
CYLINDERS	4
DISPLACEMENT	1.6 Liter
BORE	3.15
STROKE	3.13
COMPRESSION RATIO	9.75:1
INTAKE AIR SYSTEM	Naturally Aspirated
VALVE SEATS	Replaceable
LIFTER TYPE	Hydraulic

GOVERNOR SPECIFICATIONS

TYPE	Electronic
FREQUENCY REGULATION	Isochronous
STEADY STATE REGULATION	± 0.25%

ENGINE LUBRICATION SYSTEM

OIL PUMP	Gear
OIL FILTER	Full flow spin-on cartridge
CRANKCASE CAPACITY	4 Quarts

ENGINE COOLING SYSTEM

TYPE	Closed
WATER PUMP	Belt driven
FAN SPEED	2550
FAN DIAMETER	15 inches
FAN MODE	Pusher

FUEL SYSTEM

FUEL TYPE	Natural gas, propane vapor
CARBURETOR	Down Draft
SECONDARY FUEL REGULATOR	Standard
FUEL SHUT OFF SOLENOID	Standard
OPERATING FUEL PRESSURE	5" - 14" H ₂ O

ELECTRICAL SYSTEM

BATTERY CHARGE ALTERNATOR	12V 30 Amp
STATIC BATTERY CHARGER	2 Amp
RECOMMENDED BATTERY	Group 26, 525CCA
SYSTEM VOLTAGE	12 Volts

OPERATING DATA			
KW RATING (LP/NG)	30/27		
ENGINE SIZE	1.6 Liter 4 cyl. inline		
GENERATOR OUTPUT VOLTAGE/KW - 60Hz	KW	AMP	CB Size
120/240V, 1-phase, 1.0 pf	30	125	150
120/208V, 3-phase, 0.8 pf	30	104	125
120/240V, 3-phase, 0.8 pf	30	90	100
ENGINE FUEL CONSUMPTION (Natural Gas) (Propane)	Natural Gas (ft ³ /hr.)		Propane (gal/hr.) cu ft/hr
Exercise cycle	60		0.7 24
25% of rated load	145		1.6 58
50% of rated load	260		2.8 103
75% of rated load	370		4.0 147
100% of rated load*	470		5.1 187
ENGINE COOLING			
Air flow (inlet air including alternator and combustion air)	ft ³ /min.	1,800	
System coolant capacity	US gal.	2.0	
Heat rejection to coolant	BTU/hr.	131,000	
Max. operating air temp. on radiator	°C (°F)	60 (150)	
Max. ambient temperature	°C (°F)	50 (140)	
COMBUSTION AIR REQUIREMENTS			
Flow at rated power 60 Hz	cfm	95	
SOUND EMISSIONS IN DBA			
Exercising at 7 meters		62	
Normal operation at 7 meters		72	
EXHAUST			
Exhaust flow at rated output 60 Hz	cfm	260	
Exhaust temp. at muffler outlet	°F	1025	
ENGINE PARAMETERS			
Rated synchronous RPM	60 Hz	3600	
POWER ADJUSTMENT FOR AMBIENT CONDITIONS			
Temperature Deration	3% for every 10 °C above - °C	25	
	1.65% for every 10 °F above - °F	77	
Altitude Deration	1% for every 100 m above - m	183	
	3% for every 1000 ft. above - ft.	600	

* Refer to "Emissions Data Sheets" for maximum fuel flow for EPA and SCAQMD permitting purposes.

RATING: All three phases units are rated at 0.8 power factor. All single phase units are rated at 1.0 power factor. **STANDBY RATING:** Standby ratings apply to installations served by a reliable utility source. The standby rating is applicable to varying loads for the duration of a power outage. There is no overload capability for this rating. Ratings are in accordance with ISO-3046-1. Design and specifications are subject to change without notice.
KW rating is based on LPG Fuel and may derate with natural gas.

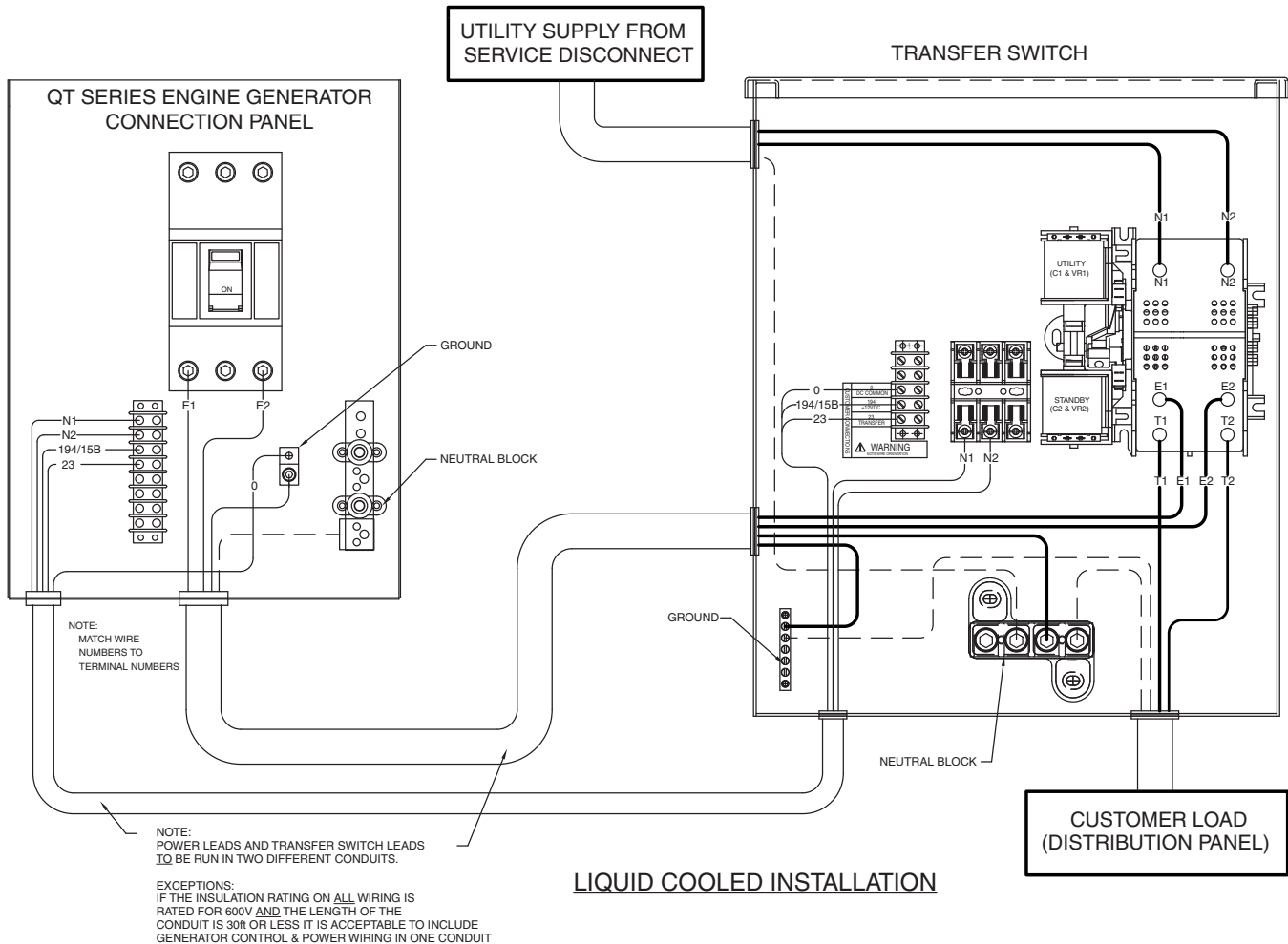

NEXUS™ CONTROL FEATURES

2-Line Plain Text LCD Display	Simple user interface for ease of operation
Mode Switch	Automatic Start on Utility failure. 7 day exerciser
-Auto	
-Off	Stops unit. Power is removed. Control and charger still operate.
-Manual/Test (start)	Start with starter control, unit stays on. If utility fails, transfer to load takes place.
Programmable start delay between 10-30 seconds	Standard
Engine Start Sequence	Cyclic cranking: 16 sec. on, 7 rest (90 sec. maximum duration)
Engine Warm-up	5 seconds
Engine Cool-Down	1 minute
Starter Lock-out	Starter cannot re-engage until 5 sec. after engine has stopped.
Smart Battery Charger	Standard
Automatic Voltage Regulation with Over and Under Voltage Protection	Standard
Automatic Low Oil Pressure Shutdown	Standard
Overspeed Shutdown	Standard, 72Hz
High Temperature Shutdown	Standard
Overcrank Protection	Standard
Safety Fused	Standard
Failure to Transfer Protection	Standard
Low Battery Protection	Standard
50 Event Run Log	Standard
Future Set Capable Exerciser	Standard
Incorrect Wiring Protection	Standard
Internal Fault Protection	Standard
Common External Fault Capability	Standard
Governor Failure Protection	Standard

*Single and three phase connections may vary, refer to the owner's manual for specific connection information.

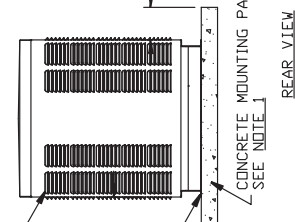
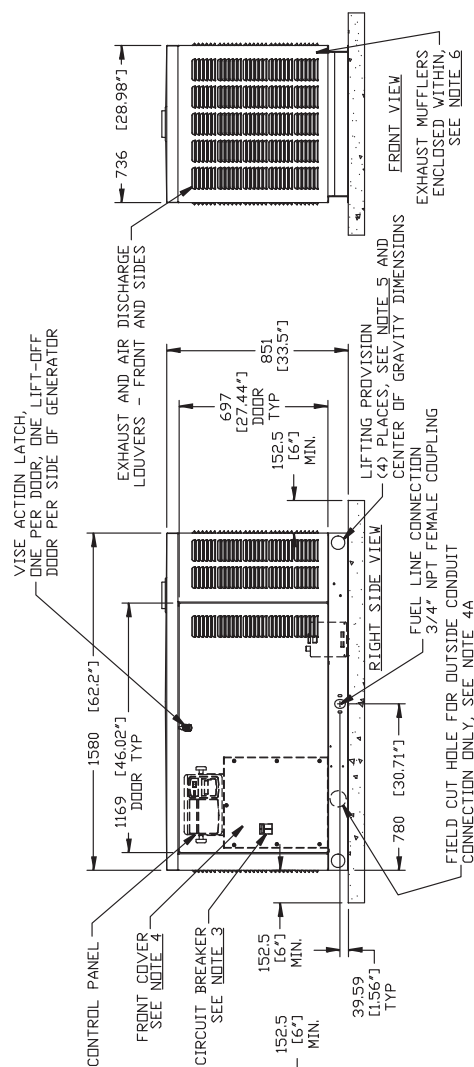
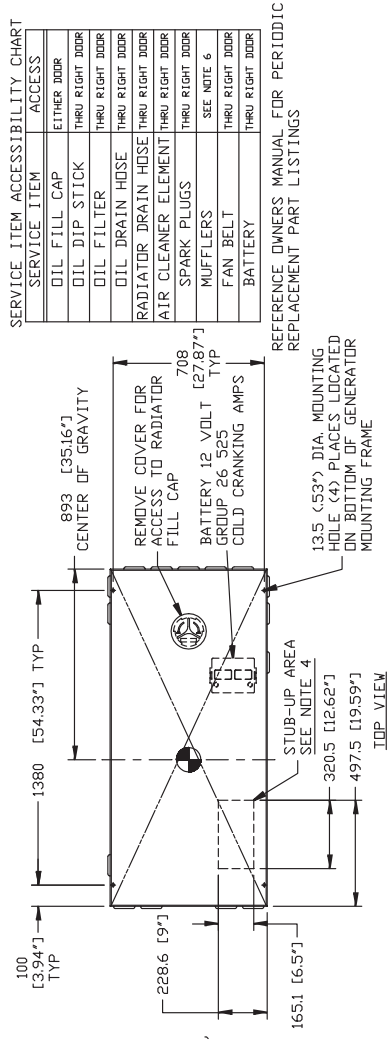

SERVICE ITEM ACCESSIBILITY CHART

SERVICE ITEM	ACCESS
OIL FILL CAP	EITHER DOOR
OIL DIP STICK	THRU RIGHT DOOR
OIL FILTER	THRU RIGHT DOOR
OIL DRAIN HOSE	THRU RIGHT DOOR
RADIATOR DRAIN HOSE	THRU RIGHT DOOR
AIR CLEANER ELEMENT	THRU RIGHT DOOR
SPARK PLUGS	THRU RIGHT DOOR
MUFFLERS	SEE NOTE 6
FAN BELT	THRU RIGHT DOOR
BATTERY	THRU RIGHT DOOR

REFERENCE OWNERS MANUAL FOR PERIODIC REPLACEMENT PART LISTINGS

- NOTES:**
- 1) MINIMUM RECOMMENDED CONCRETE PAD SIZE: 1041 (41.0') WIDE X 1892 (74.5') LONG. REFERENCE INSTALLATION GUIDE SUPPLIED WITH UNIT FOR CONCRETE PAD GUIDELINES.
 - 2) ALLOW SUFFICIENT ROOM ON ALL SIDES OF THE GENERATOR FOR MAINTENANCE AND SERVICING. THIS UNIT MUST BE INSTALLED IN ACCORDANCE WITH CURRENT APPLICABLE NFPA 37 AND NFPA 70 STANDARDS AS WELL AS ANY OTHER FEDERAL, STATE AND LOCAL CODES FOR MINIMUM DISTANCES FROM OTHER STRUCTURES.
 - 3) CIRCUIT BREAKER INFORMATION: SEE SPECIFICATION SHEET WITHIN OWNERS MANUAL
 - 4) INSIDE STUB-UP AREA FOR AC LOAD LEAD CONDUIT CONNECTION, NEUTRAL CONNECTION, BATTERY CHARGER 120 VOLT AC (< 5 AMP MAX.) CONNECTION, ACCESS TO TRANSFER SWITCH CONTROL WIRES, AND TRANSFER SWITCH CONNECTION (IF SO EQUIPPED). REMOVE FRONT COVER FOR ACCESS.
 - 4A) FIELD CUT HOLE IS ONLY REQUIRED FOR MOUNTING OF GENERATOR ON AN EXISTING PAD.
 - 5) REFERENCE OWNERS MANUAL FOR LIFTING WARNINGS.
 - 6) REMOVE LIFT-OFF ENCLOSURE TO ACCESS EXHAUST MUFFLER.

WEIGHT DATA

ENCLOSURE MATERIAL	NET WT (GENSET ONLY) KG (LBS)	WEIGHT (MODERN SHIPPING CRATE) KG (LBS)	SHIPPING WEIGHT (GENSET AND CRATE) KG (LBS)
1. 6L/18K ALUMINUM	424 (935)	127 (280)	551 (1215)
1. 6L/20K STEEL	383 (845)	127 (280)	510 (1125)
1. 6L/25K ALUMINUM	356 (785)	127 (280)	483 (1065)
1. 6L/25K STEEL	397 (875)	127 (280)	524 (1155)
1. 6L/30K ALUMINUM	356 (785)	127 (280)	483 (1065)
1. 6L/30K STEEL	424 (935)	127 (280)	551 (1215)
ALUMINUM	383 (845)	127 (280)	510 (1125)

